

**TECHNICAL DATA**

$U_{max}$	7.0 V	$T_{hot}=25^{\circ}C$ Dry air
$Q_{max}$	28.6 W	
$\Delta T_{max}$	68°	
$I_{max}$	6.4 A	
ACR at 25°C	1.0 Ohm	
Hot side	Ceramics $Al_2O_3$ , white 96%	
Cold side		
Max. processing temperature	Depends on chosen solder type	
Standard tolerances for thermal and electrical parameters $\pm 10\%$		

**STANDARD ORDERING OPTIONS**

Nº	Option	Parameter		
1	Lead wires	AWG Nº		
		18	20	22
2	Lead wires length	L - under customer request		
3	Lead wires insulation	Type / Max. processing temp.		
		Without insulation / See solder type m.p.t		
		PVC / 105° C		
		Silicone / 180° C		
4	Internal solder	Type / Max. processing temp.		
		Type-1 / 138° C		
		Type-2 / 227° C		
		Type-3 / 232° C		
		Type-4 / 290° C *		
5	Anticorrosional coating	yes	no	
6	Sealing	Type / Max. processing temp.		
		Without sealing / 200° C		
		Epoxy / 130° C		
		Silicone / 180° C		

**MODULE DRAWING**  
standard design

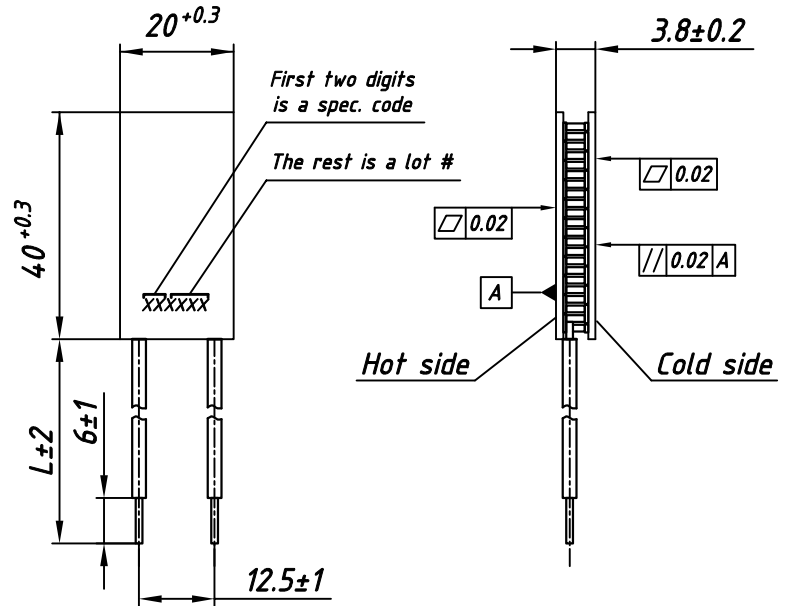

**AVAILABLE MODIFICATIONS**

Design	Description
TM-63-1.4-6.0 M	High reliable version on cold side

**OPTIONS UPON REQUEST**

Height tolerance	$\pm 0.02$
Unflatness and nonparallelism	$\pm 0.02$

- Solder type marked \* is not compliant to RoHS (2002/95/EC)
- For another options consult of our technical support engineers