

TECHNICAL DATA

| | | |
|--|--------------------------------|----------------------------------|
| U_{max} | 27.1 V | $T_{hot}=25^{\circ}C$ Dry air |
| Q_{max} | 318 W | |
| ΔT_{max} | 68° | |
| I_{max} | 19.6 A | |
| ACR at 25°C | 1.23 Ohm | |
| Hot side | Ceramics Al_2O_3 , white 96% | |
| Cold side | | |
| Max. processing temperature | Depends on chosen solder type | |
| Standard tolerances for thermal and electrical parameters $\pm 10\%$ | | |

STANDARD ORDERING OPTIONS

| Nº | Option | Parameter | |
|----|-------------------------|--|----|
| 1 | Lead wires | AWG Nº | |
| | | 18 | 20 |
| 2 | Lead wires length | L - under customer request | |
| 3 | Lead wires insulation | Type / Max. processing temp. | |
| | | Without insulation / See solder type m.p.t | |
| | | PVC / 105° C | |
| | | Silicone / 180° C | |
| 4 | Internal solder | Type / Max. processing temp. | |
| | | Type-1 / 138° C | |
| | | Type-2 / 227° C | |
| | | Type-3 / 232° C | |
| 5 | Anticorrosional coating | yes | no |
| | | Type / Max. processing temp. | |
| 6 | Sealing | Without sealing / 200° C | |
| | | Epoxy / 130° C | |
| | | Silicone / 180° C | |

MODULE DRAWING
standard design

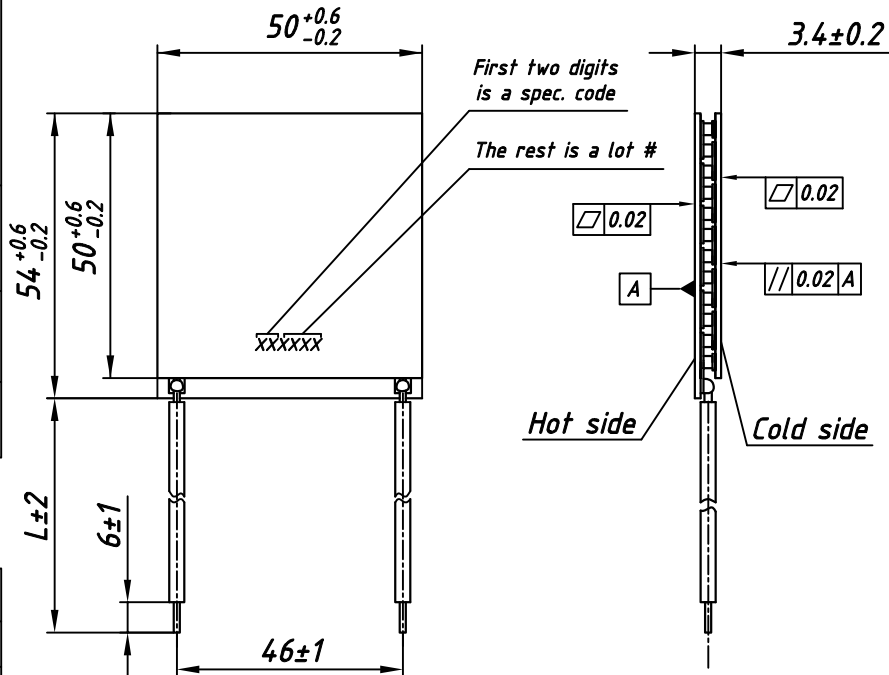

AVAILABLE MODIFICATIONS

| Design | Description |
|--------------------|---|
| TM-241-1.6-20.0 MM | Porch-style design with high reliable version on both sides |

OPTIONS UPON REQUEST

| | |
|-------------------------------|------------|
| Height tolerance | ± 0.02 |
| Unflatness and nonparallelism | ± 0.02 |

- Solder type marked * is not compliant to RoHS (2002/95/EC)
- For another options consult of our technical support engineers