

***RMT Ltd.***  
*Joint Stock Company*

**Optical Unit  
DX6106 Series**

***User Guide***



2002  
Rev. 1.10

## **Edition April 2002**

### **Copyright**

All right reserved. Reproduction in any manner, in whole or in part is straightly prohibited without written permission of RMT Ltd  
The information contained in this document is subject to change without notice.

### **Limited Warranty**

RMT Ltd warrants that DX6106 Optical Unit, if properly used and installed, will be free from defects in material and workmanship and will substantially conform to RMT's publicly available specification for a period of one (1) year after date of DX6106 Optical Unit was purchased.

If the DX6106 Optical Unit which is the subject of this Limited Warranty fails during the warranty period for the reasons covered by this Limited Warranty, RMT, at this option, will :

**REPAIR** the DX6106 Optical Unit; **OR**

**REPLACE** the DX6106 Optical Unit with another DX6106 Optical Unit.

### **Trademark Acknowledgments**

All trademarks are the property of their respective owners.

RMT Ltd. 53 Leninskij prosp. Moscow 119991 Russia  
phone: 095-132-6817 fax: 095-132-5870  
e-mail: rmtcom@dol.ru <http://www.rmtltd.ru>

## **Contents**

1. Introduction	1–1
2. Theory of Operation	
Principles of Operation	2–1
Design Features	2–4
Operation Overview	2–5
3. Construction of Optical Unit	3–1
Gas Sampling Cell	3–2
Optocomponent	3–5
6102 Optocomponent Mating Module	3–7
Preamplifier	3–10
Thermoelectric Cooler	3–13
Thermistor	3–19
Light Emitters	3–24
EEPROM	3–27
EEPROM Data Format	3–30
4. Installation Tips	4–1
5. Calibration	5–1
Preparation	5–1
Zero Adjustments	5–3
Re–Calibration	5–4
6. Maintenance	
Optics Cleaning	6–1
7. Standard Kit	7–1
8. Specifications	8–1
9. Ordering Guide	9–1



## **1. Introduction**

The company RMT Ltd introduces new DX6106 series of Optical Units for gas measurement systems.

The principle of operation is based on selective absorption of IR radiation by gas molecules.

The differential double frequency optical scheme provides high accuracy in wide ranges of humidity and temperature due to the internal thermostabilization.

New type of middle infrared combined optocomponent with built-in thermoelectric cooling is used.

There are several models suitable for the following gases : CO<sub>2</sub>, CH<sub>4</sub>, C<sub>n</sub>H<sub>m</sub>, water vapor.

### ***Advantages***

- ***high selectivity and stability***
- ***wide range of measured concentrations***
- ***fast response***
- ***no direct contact of sensitive element with measured gas***
- ***the long service life***

### ***Features***

- ***no moving parts***
- ***minimum dimensions and light weight***
- ***low power consumption***



## 2. Theory of Operation

### Principles of Operation

The NDIR (Non-Dispersive Infra-Red Spectroscopy) measurement method is implemented in the DX6106 Optical Unit.

The device provides gases concentration measurement based on the classical double channel optical scheme (Fig. 2.1). One of the beams (measuring channel) has the wavelength which is tuned to the optical absorption line of the measured gas. The other beam (reference channel) has the wavelength which is out of the adsorption band of the measured gas.

Intensities of two light beams that passed through the measured gas sampling cell are compared.

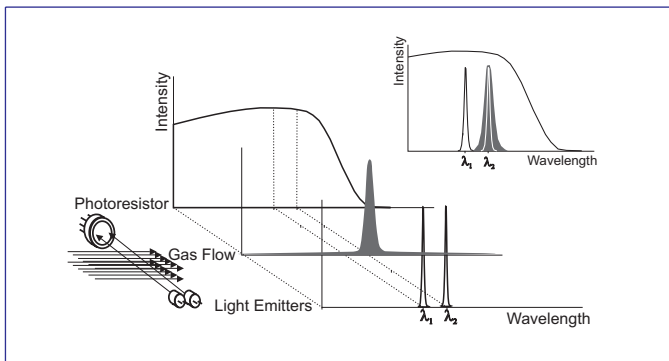

*Fig. 2.1. The principle of gas concentration*

According to the Beer–Bouguer–Lambert law, light absorption in a gas volume is proportional to the absorbing gas concentration:

$$I = I_0 \cdot e^{-\alpha LX}$$

where

- $I_0$  – intensity of light before pass through the gas volume;
- $I$  – intensities of light after pass through the gas volume;
- $\alpha$  – absorption coefficient of the gas at the chosen light wavelength;
- $L$  – optical pass length;
- $X$  – gas concentration.

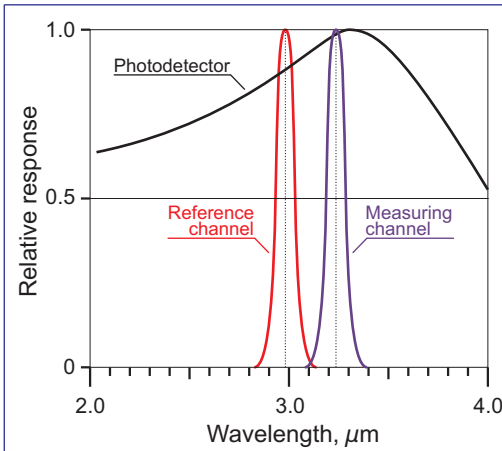
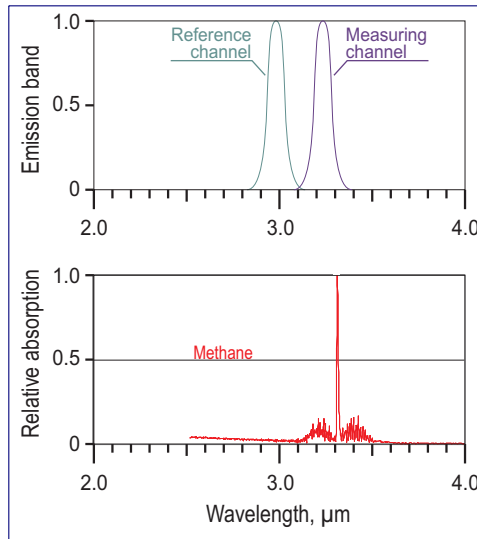

*Fig. 2.2. Spectral bands of light emitters for methane analyzer*

At a fixed  $L$  and known absorption  $\alpha$  it is possible to find gas concentration using measured intensity of light (measuring channel) that passed from Light Emitter to Photodetector.



Reference channel is used for indirect measuring of the initial intensity of light, and allows to eliminate actual measurements conditions (total transparency of gas volume, optics imperfection and so on).



*Fig. 2.3. Spectral bands of light emitters and methane*

In Fig. 2.2 the example of spectral bands of light emitters for methane analyzer is shown.

The detailed description of the optocomponent is given in Chapter 3.

In Fig. 2.3 the spectral bands of light emitters of the optopair are given in comparison with methane absorption spectra.

## Design Features

The DX6106 Optical Unit is specially designed for a fast response, high sensitivity, low noise and low power consumption.

A number of design features contribute to the performance :

- The infrared sources are special narrow–band pulsed Light Emitters which operate in microsecond range. The light sources have long life (more then 10,000 hours).
- Radiation from Light Emitters passes through the gas sampling cell, reflects from the mirror and is focused onto the wide–band Photodetector.
- Both Light Emitters and Photodetector chips are integrated into a single housing and placed onto a miniature TE cooler for thermostabilization.
- Heat, dissipated from warm side of the TE cooler, leads to few degrees of overheating of gas sampling cell above ambient. This factor plays a role of vapor anti–condensation at operation in wet conditions.
- For signal processing the calibrating data of Optical Unit is used. The data is stored in Optical Unit's EEPROM.

## Operation Overview

*The subsequent description assumes User has already developed, manufactured and connected to the Optical Unit some electronic device for Optical Unit management. (See recommendations in Chapter 3).*

The order of measurements with DX6106 device is as follows:

1. Firstly, individual calibration of device is required with using of standard gas mixtures.

The Detector output signal is non-linear with respect to measuring gas concentration. In spite of theoretical formula the intensity of light which passed through gas sampling cell, is the integral of various optical rays from Light Emitter. Also sensitivity of Detector and performance of Light Emitter are very sensitive to its operating temperatures.

Detector's output signals (both measuring  $U_m$  and reference  $U_r$  channels) must be measured to calculate the following  $D$  ratio as a function of known concentration  $X$  of standard mixtures.

Zero ratio  $D_0 = f(X=0)$  at zero gas concentration should be used for polynomial extrapolation of calibration results as:

$$D = \frac{U_m}{U_r}$$

$$Y = \frac{D_0}{D}$$

$$X = A_0 + A_1 \cdot Y + A_2 \cdot Y^2 + A_3 \cdot Y^3 + A_4 \cdot Y^4$$

Calculated coefficients  $A_0 \dots A_4$  of polynomial expression and zero ratio  $D_0$  may be stored into device internal on-board EEPROM memory.

The first calibration is made by Manufacturer.

The factory standard calibration uses not less than 5 standard gas mixtures.

Several calibrations as above described are made at different ambient temperatures (in a specified operating range) and at corresponding optimal operating temperatures of integrated detector-emitter pair.

Up to 15 such calibrations are possible to store for further application.

Format of calibration data stored in the EEPROM memory chip after manufacturer calibration is described below in Chapter 3.

2. During routine operation the detector's output signals should be measured to calculate  $D$  ratio. Using known "zero" ratio  $D_0$  value  $Y$  is calculated.

Finally, using known polynomial coefficients  $A_0 \dots A_4$  gas concentration  $X$  may be calculated with high accuracy.

3. To preserve high accuracy of the device it is necessary to do “zero” adjustments periodically as recommended in Chapter 5.

4. Periodicity of device recalibration is 1 year. It could be done at the factory of Manufacturer, or by a User.



### **3. Construction of Optical Unit**

The DX6106 Optical Unit (Fig. 3.1 and 3.2) consists of an isolated gas sampling cell (the spherical mirror and the flat mirror with a hole are placed at the end sides) and a new generation integrated optopair with 6102 electronic module.

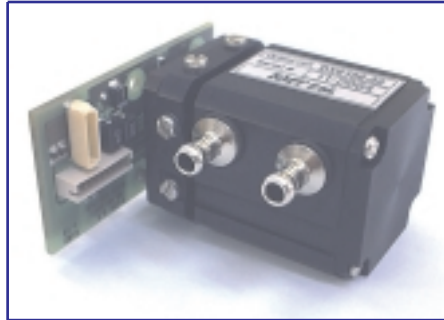

The 6102 Optocomponent Mating Module is connected to optopair's leads and is fixed with two screws on a bottom cover of the gas sampling cell.

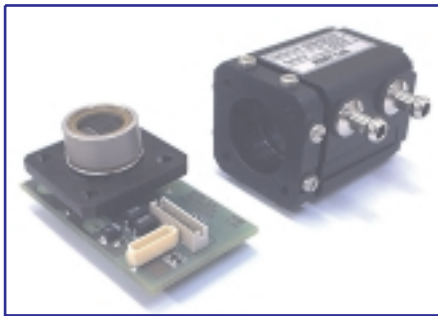

*Fig. 3.2. DX6106 Optical Unit with optopair detached*

## Gas Sampling Cell



*Fig. 3.3. DX6106.C40 gas sampling cell*

The body of gas sampling cell is made of anodized aluminum alloy (Fig. 3.3). It has two gas inlets with 5.0 mm internal diameter.

The gas sampling cell can be easily disassembled for service of internal optics (mirrors and optopair).

For this purpose both the top and bottom covers can be removed and the optical components extracted out.

The gas sampling cell design is shown in Fig. 3.4.

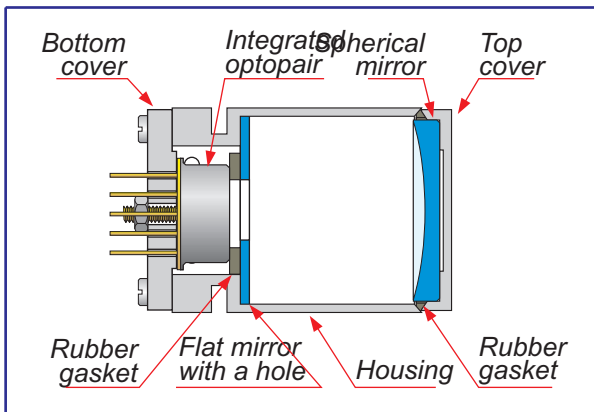

*Fig. 3.4. Gas sampling cell design*



The optical scheme of gas cell is represented in Fig. 3.5.

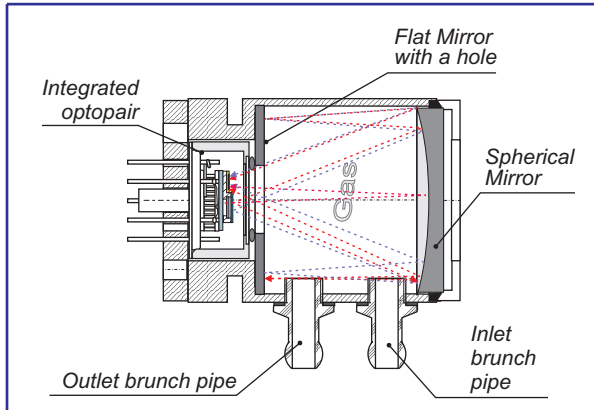

The main parameters of gas sampling cell are in Table 3.1

*Table 3.1. Main parameters of gas*

Parameter	Value
No. of passes	4
Total path length, mm	80
Internal volume, ml	10.4

The outline dimensions of DX6106.C40 gas sampling cell are shown in Fig. 3.6.

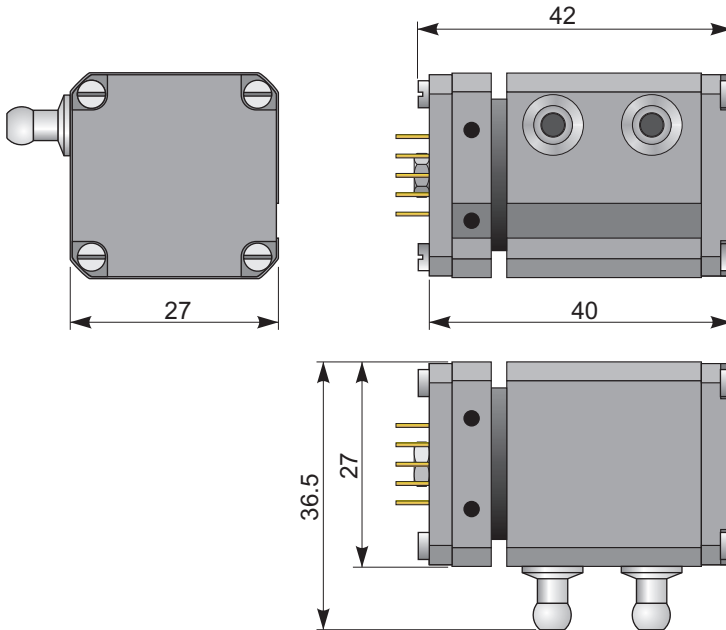

*Fig. 3.6 DX6106.C40 gas sampling cell outline dimensions (in millimeters)*

## Optocomponent

The new generation OPRI optopair consists of three optoelements integrated into one case : two narrow – band light emitters (of about  $0.1 \mu\text{m}$  emission band) and one wide – band photodetector.

The optopair consists of two special solid state light emitters (light sources) and one sensitive element (photodetector).

The peak emission wavelength of one light emitter is near the absorption band of measured gas (measuring channel). The peak wavelength of the other one is out of the absorption band of gas (reference channel).

The photodetector has approximately equal sensitivity to signals of both emitters.

All the elements of the optopair are mounted onto the cooling surface of a single stage thermoelectric module of 1MT04–059–16 type with an internal thermosensor (Fig. 3.7).

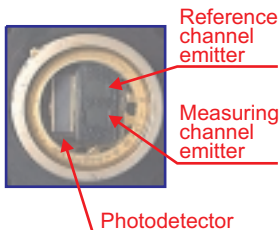

*Fig. 3.7. OPRI elements arrangement*

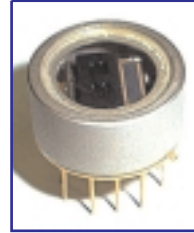

A number of steps have been taken to decrease the optoelements mutual influence.

The pins layout of the optopair is shown in Fig. 3.8.

As an example, the parameters of optoelements for methane (CH<sub>4</sub>) measurements are introduced in the table below:

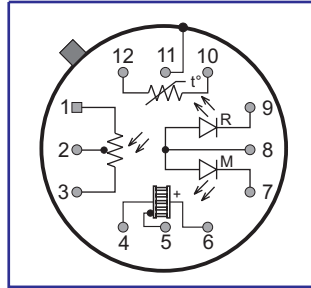

*Fig. 3.8. OPxxx optopair pins layout (top view)*

Element	Peak wavelength [ μm ]	Bandwidth [ μm ]
Measuring channel emitter	3.23	0.1
Reference channel emitter	2.98	0.1
Photodetector	3.3	2.5

The above table is illustrated with Fig. 3.9.

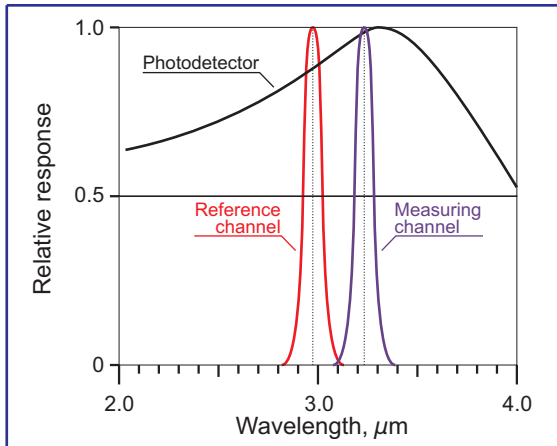
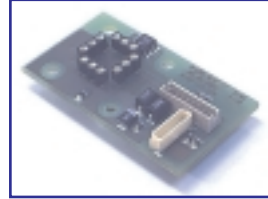

*Fig. 3.9. Emission bands of light emitters for methane analyzer*

## 6102 Optocomponent Mating Module

The 6102 Optocomponent Mating Module (Fig. 3.10) provides:

- preamplification of photodetector's signals,
- light emitters driving,
- power supply of photodetector and thermistors with precise voltage.



*Fig. 3.10. 6102 Optocomponent Mating Module*

The connectors and optopair location at the 6102 Module's board is shown in Fig. 3.11.

The outline dimensions of 6101 Module are given in Fig. 3.12.

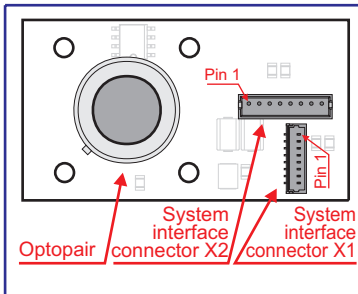

*Fig. 3.11. Location of the connectors and optopair at the 6102 Modules board.*

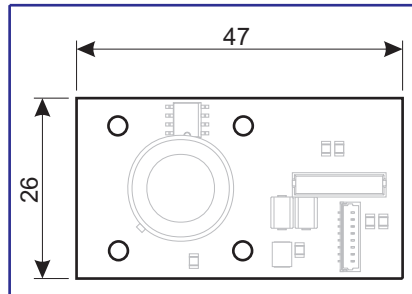

*Fig. 3.12. 6102 Module outline dimensions (in millimeters)*

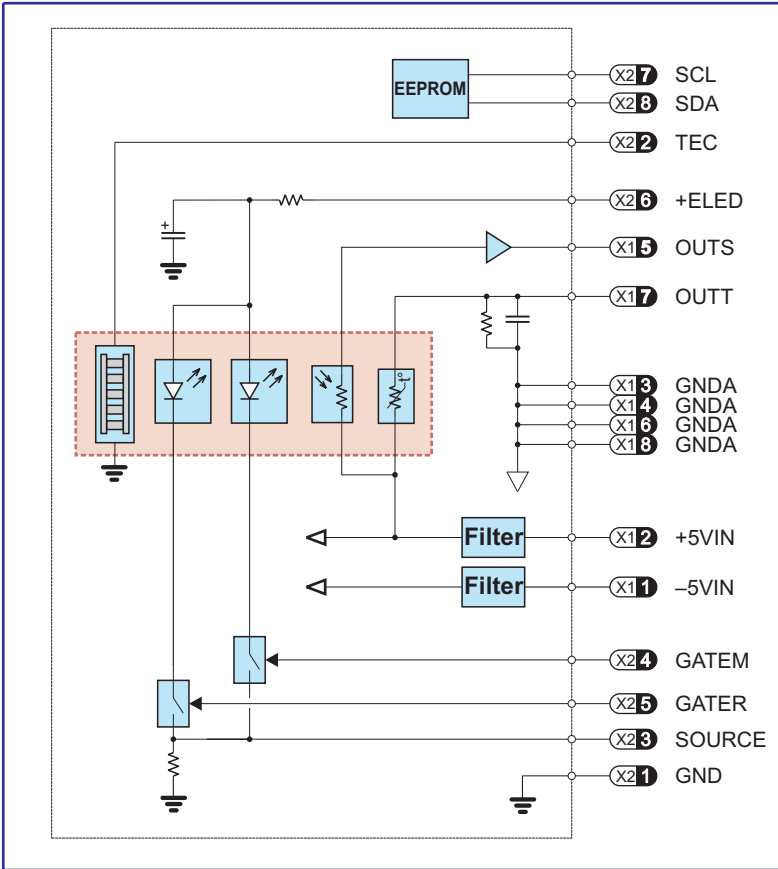

**Legend**

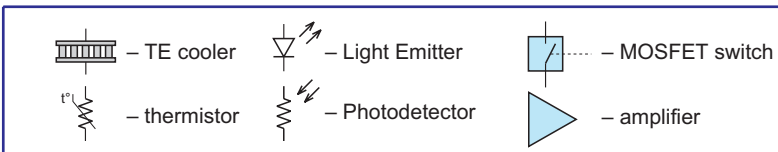

**Fig. 3.13. Functional Diagram of 6102 Optocomponent**

The functional diagram of the 6102 module is drawn in Fig. 3.13.

System interface connectors' pins assignment is given in Tables 3.2 and 3.3.

*Table 3.2. DX6106 system interface connector X1 pins function description*

Pin	Mnemonic	Description
1	<b>-5VIN</b>	- 5V supply input
2	<b>+5VIN</b>	+ 5V supply input
3	<b>GND A</b>	Ground reference point for analog circuitry and
4	<b>GND A</b>	Ground reference point for analog circuitry and
5	<b>OUTS</b>	Photodetector output
6	<b>GND A</b>	Ground reference point for analog circuitry and
7	<b>OUTT</b>	Thermistor output
8	<b>GND A</b>	Ground reference point for analog circuitry and

*Table 3.3. DX6106 system interface connector X2 pins function description*

Pin	Mnemonic	Description
1	<b>GND</b>	Ground reference point for power circuitry
2	<b>TEC</b>	Cooler power supply input
3	<b>SOURCE</b>	Current sense resistor output
4	<b>GATEM</b>	Measuring channel LED enable
5	<b>GATER</b>	Reference channel LED enable
6	<b>+ELED</b>	LEDs power supply
7	<b>SCL</b>	I <sup>2</sup> C interface. Synchronization line
8	<b>SDA</b>	I <sup>2</sup> C interface. Data line

## Preamplifier

The preamplifier's circuit diagram is presented in Fig. 3.14.

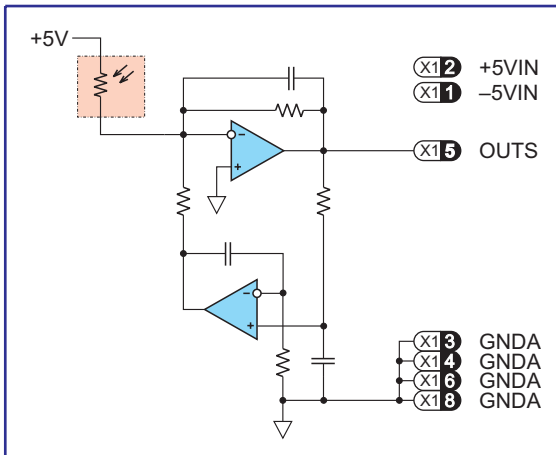

*Fig. 3.14. Simplified diagram of preamplifier of the 6102 module*

The preamplifier alternatively processes the signals of measuring and reference channels.

The preamplifier output signal should be conditioned and then digitized by A/D converter (ADC) with not worse than 12 bit resolution.

Recommended outside schematic is placed in Fig. 3.15.



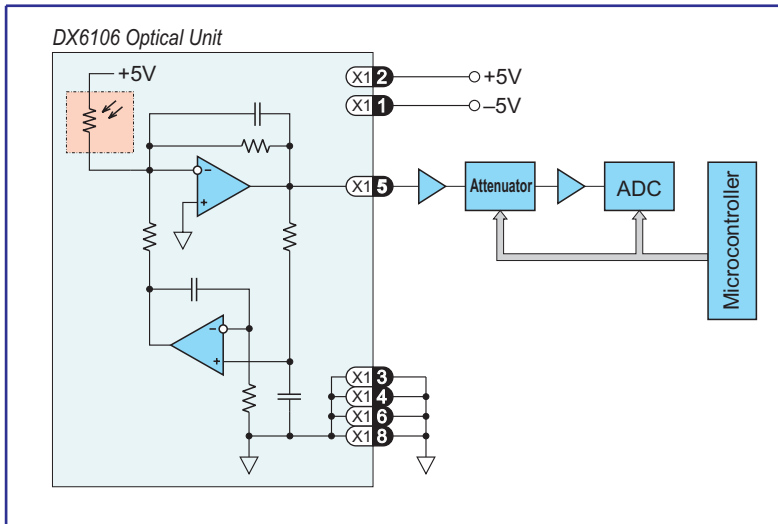

*Fig. 3.15. Output signal processing*

Within the gas concentration varying scale, the output signal of measuring channel changes by order of value. To preserve accuracy at large measuring gas concentrations it is necessary to use an external amplifier with a variable gain. It is to coordinate the amplified signal with an ADC range.

Alternatively, an attenuator may be used. The attenuator can be based on a digital potentiometer chip or D/A converter.

It is unnecessary if LEDs pumping current control scheme is implemented.

The preamplifier typical output signal waveform is shown in Fig. 3.16.

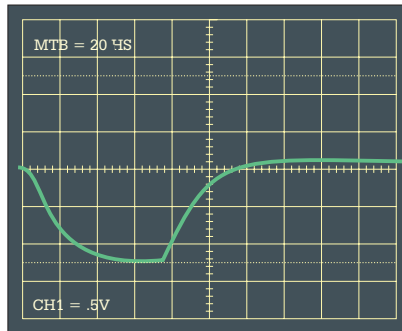

*Fig. 3.16. Typical output signal waveform*

## Thermoelectric Cooler

The TEC circuit diagram is presented in Fig. 3.17.

Driving by TE cooler requires particular attention.

First of all, the operation of TE cooler directly affects performance parameters of Optical Unit and gas sensor based on it.

Second, the TE cooler is the component which consume the largest part of power (Fig. 3.18).

The output signal of Photodetector depends very much on its temperature (Fig. 3.19).

This ratio is approximately 100%/20 °C. It is equivalent to the temperature drift 1%/0.2 °C. It means that if the thermo-stabilization should be with the accuracy of 0.1°C, then the accuracy of measurements will be 0.5%.

The accuracy of thermo-stabilization must be not less than required for gas sensing.

Operating temperature of TE cooler must be selected optimal (from Fig. 3.18 and Fig. 3.19): too low temperature stabilization leads to higher power

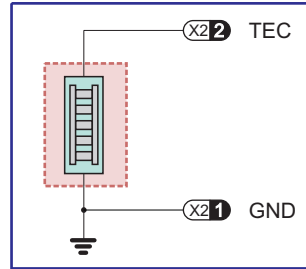

*Fig. 3.17. Schematics of TE cooler in*

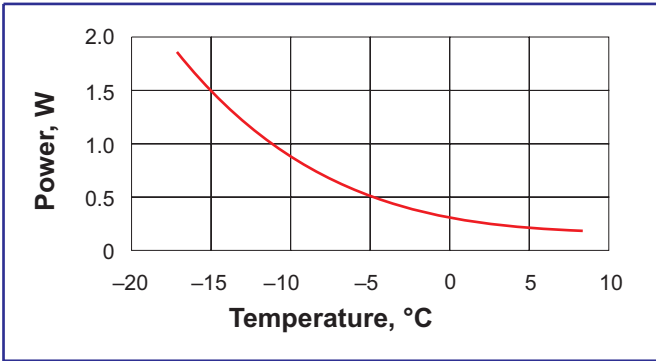

Fig. 3.18. TEC power consumption vs operating temperature

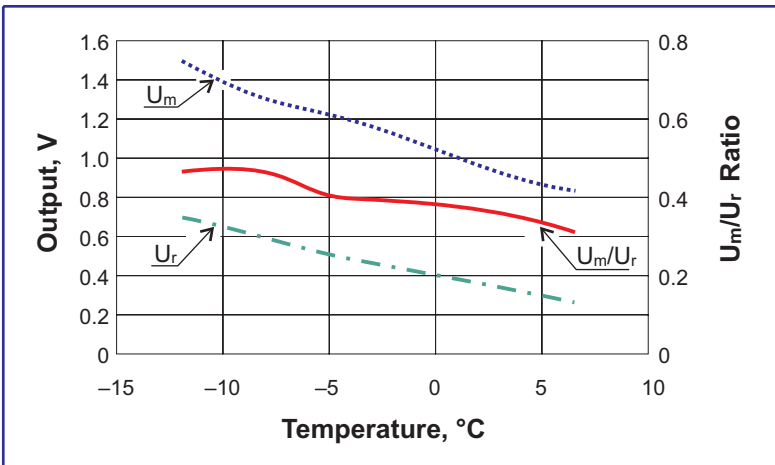

Fig. 3.19. Typical preamplifier output vs operating temperature

consumption; at higher temperature the output signals (and signal/noise ratio) are lower.

The Optical Unit housing has been designed for additional heat dissipation from warm side of working TE coolers. The maximal heat dissipation is 2 W. At  $T_a - T_{op} > 40\text{ }^{\circ}\text{C}$  it is necessary to use additional heat dissipation – a bigger heat sink (optional available) or a fan.

A developer of thermo – stabilization algorithm has to take into account that time constant of TE cooler is approximately 2 s.

An example of recommended scheme of thermo – stabilization is presented in Fig. 3.20.

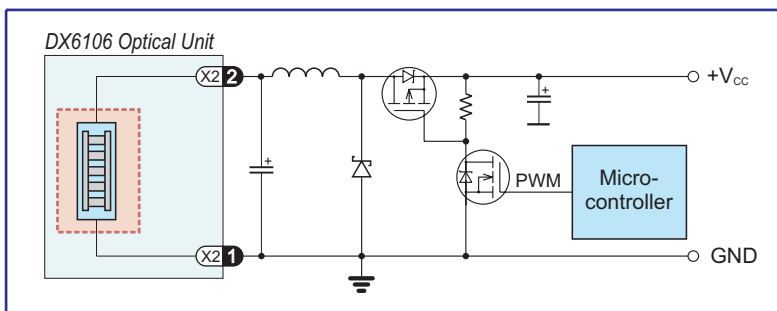

If step-down DC/DC converter is used, the  $V_{CC}$  voltage should be not less than 7V to provide the appropriate range of TEC control voltage.

The maximum converter's output current is determined by TECs characteristics behavior. (See Fig. 3.21).

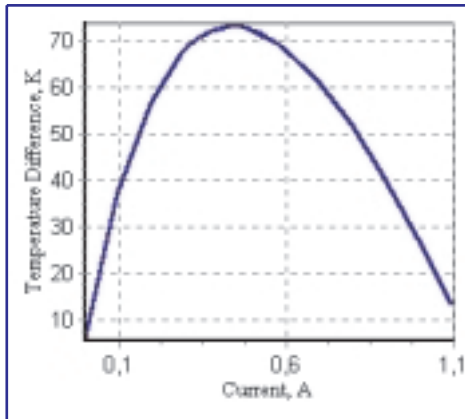

*Fig. 3.21. Maximal temperature difference vs operating current for 1MT04-059-16. (At zero heat load)*

As one can see in this diagram, there is some peak current value, the efficiency of TE cooler falls down after that.

It is obvious, that the exceeding of this parameter is not meaningful. So 0.5 amp can be considered as an upper bound of a DC/DC converter load.

**TE Cooler Specifications**T<sub>AMB</sub> = +20°C

Parameter	Units	Min	Typ	Max	Comments
<u>Electrical Parameters</u>					
Operating T	°C	-40			
Operating Voltage	V			6.8	
Operating Current	A			0.5	
Resistance	Ohm	11.1	11.7	12.3	1 kHz @ +20°C
<u>Dynamical Parameters</u>					
Time Constant	s			2	





## Thermistor

For a TE cooler temperature controlling NTC thermistor is mounted onto the cold side of a TE cooler. This thermistor is applied in a scheme with serial loading resistor  $R_L$  and a reference  $U_{REF}$  (Fig. 3.22).

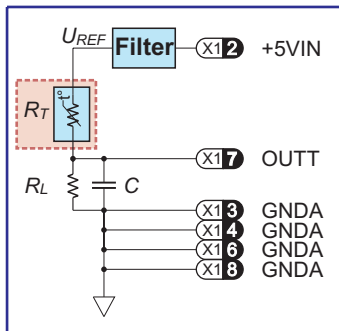
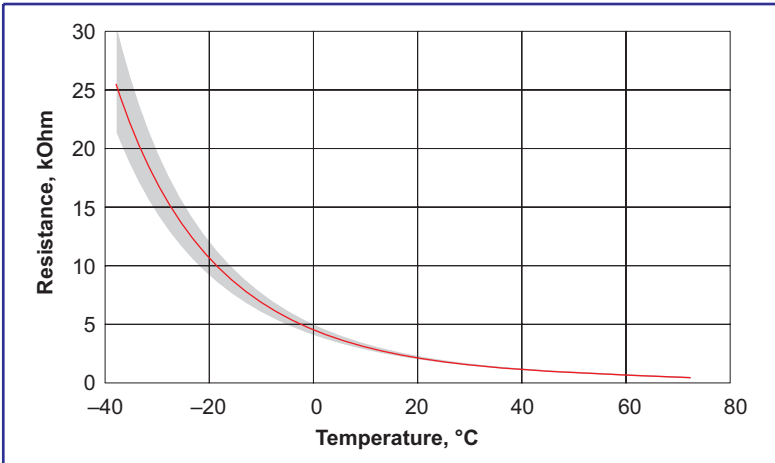

Fig. 3.22. Thermistor connection in the 6102

### Component list

Designation	Value
$R_T$	2.2 k $\Omega$ $\pm$ 5%
$R_L$	3.83 k $\Omega$ $\pm$ 0.1%
$C$	0.1 $\mu$ F, ceramic

The typical dependence of thermistor resistance on temperature is presented in Fig. 3.20. The dark area around the curve marks technological deviation determined by resistance and Beta Constant straggling from rated values.



*Fig. 3.23. Calibration of thermistor vs measured temperature*

The curve in Fig 3.23 is plotted on the basis of the fundamental equation

$$R = R_0 e^{\beta \left( \frac{1}{T} - \frac{1}{T_0} \right)} \quad (3.1)$$

where

- $\beta$  – Beta Constant,
- $R_0$  – resistance at standard temperature  $T_0$ .

The output signal from thermistor scheme depends on its resistance as :

$$U_{TR} = U_{REF} \left( \frac{R_L}{R_L + R_T} \right) \quad (3.2)$$

One can see that the temperature measurement accuracy depends directly on  $U_{REF}$ . So the voltage +5V<sub>IN</sub> on the pin X1/2 must be stable.

With the help of equations (3.1) and (3.2) we obtain the plot in Fig. 3.24.

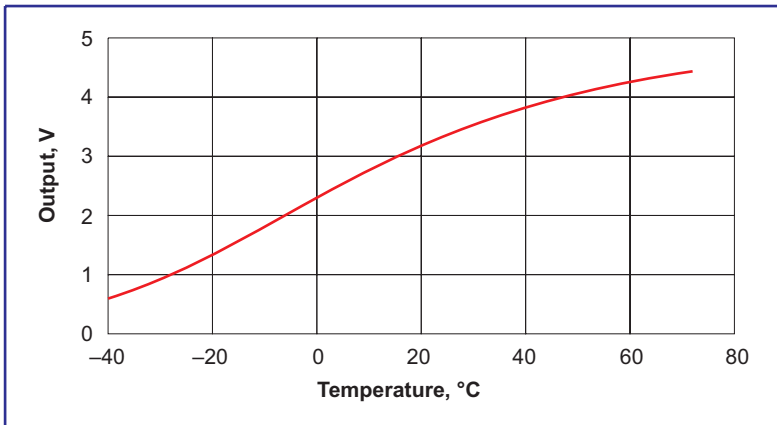

Fig. 3.24. Thermistor circuit output vs measured temperature

It is obvious that the scheme responds to temperature in a nonlinear manner. At the same time over a limited temperature range it is possible to consider the scheme response as linear.

It is also obvious that the solution of this problem should be based on the usage of a microcontroller. A look-up table for temperature measurements linearization must be formed in the external memory. The table may be located in the Optical Unit's EEPROM or in another memory chip. The base points of this table must correspond to the set of operating temperatures of the Optical Unit (See Chapter "Calibration").

In a vicinity of each point the response of the scheme should be linearized. The total number of points must be equal to the number of calibration tables (the number of operating temperatures ranges).

The recommended external circuit schematic is presented in Fig. 3.25. Not worse than 12-bit resolution A/D converters (ADCs) are recommended.

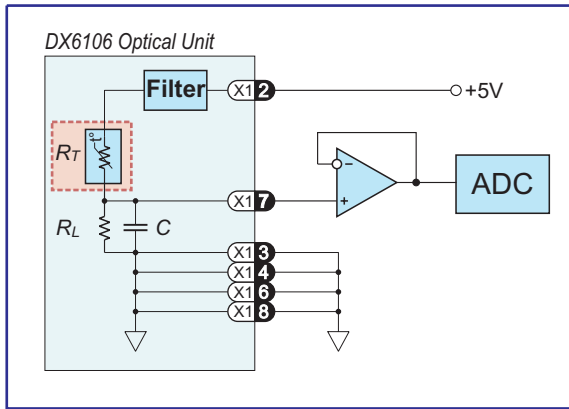

Fig. 3.25. Typical thermistor usage

### Thermistors Specifications

$T_{AMB} = +20^{\circ}\text{C}$ ;  $V_{CC} = 5 \pm 5\% \text{ V}$

Parameter	Units	Min	Typ	Max	Comments
Resistivity	kOhm	2.09	2.2	2.31	@20°C
Beta-Constant	$\text{K} \cdot 10^{-3}$	2.9	3.1	3.5	



Power Supply 5 V  
(+4... +6 V are available) through resistor R charges the capacitor C in time duration between pulses. Total capacity (the capacitor C and available external ones) must be enough for pulse current stability.

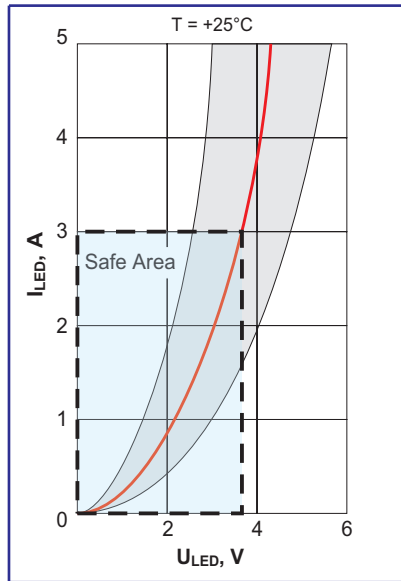

Fig. 3.27. Typical volt – ampere

#### Component list

Designation	Value
$R_E$	$4.7 \Omega \pm 5\%$
$R_S$	$0.22 \Omega \pm 5\%$
C	$2 \times 220 \mu\text{F } 6.3\text{V}$

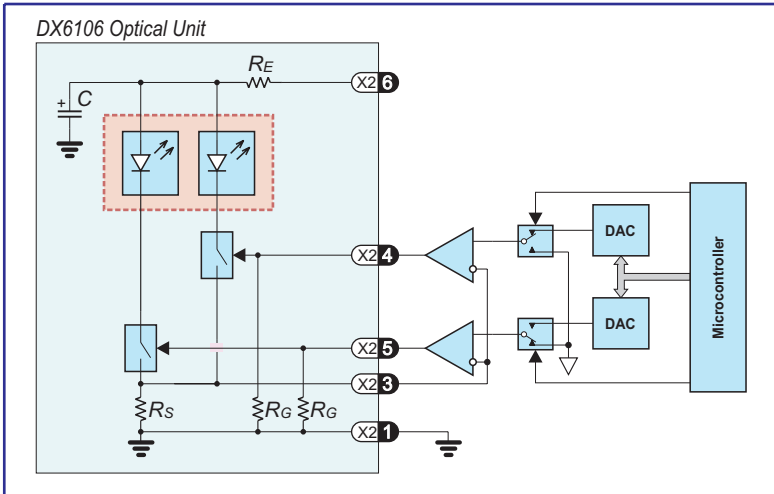

Fig. 3.28. Typical LED control circuit

It is advisable in the real design to use some number of analog multiplexors to distribute, for example, the signal of single DAC into two OPs or output signal of one OP into two MOSFET gates. It will enable to spare some equipment.

The current limiting and stabilizing circuit must be implemented essentially into LED driving circuit. It is because of the following reasons:

- The only current limiting factor is the  $R_S = 0.22$  Ohms sense resistor. (The MOSFET  $R_{ON}$  resistance is negligible in comparison with  $R_S$ ).It



is easy to plot the load line (the curve in Fig.3.X) and to see that the forward current through the LED can run up to 5 amperes if +ELED voltage is chosen as 6V.

- There is some difference of a photodetector's response to measuring and reference channel LEDs emittance. To decrease the dynamic range losses, the emitting powers of both LEDs should be balanced.

## EEPROM

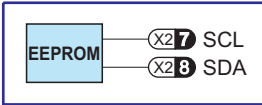
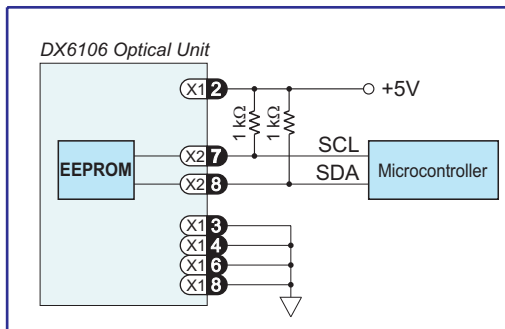

*Fig. 3.21. I<sup>2</sup>C interface connection*

The standard Electrically Erasable PROM (EEPROM) 24LC64 chip with two wire serial

I<sup>2</sup>C interface is placed on Optical Unit's PCB. It is used for storage of the Optical Unit identification

code, calibration data and some additional data for operation of the unit. Additional data are used for operation of the Optical Units with manufacturer's controller DX6101. In no power state the data retention time is more than 200 years.



*Fig. 3.22. On-board Memory typical connection*

The recommended schematic for EEPROM connection is presented in Fig. 3.22. Pay attention to the 1 kOhm resistors that must pull-up the lines of I<sup>2</sup>C interface.

The detailed description of 24LC64 transfer protocol is possible to obtain, for example, from Data sheet retrieved from Microchip Corporation Web site (<http://www.microchip.com>).

Besides the similar memory devices, are manufactured by other corporations. For example Atmel, Fairchild, ST Microelectronics, etc.

### **EEPROM Specification**

<b>Parameter</b>	<b>Value</b>
Volume, bit	16 K (2K×8)
Number of re-writing cycles, not less than	$10 \cdot 10^6$
Write speed, ms	5

## **EEPROM Data Format**

Various operating parameters can be stored in on-board EEPROM circuit:

- calibration data,
- synchronization parameters,
- measuring mode presets,
- TE cooling algorithm presets,
- Optical Unit identification.

See recommended EEPROM data structure in Table 3.4.

The formats of the First Calibration Data Block is given in Table 3.5.

Formats of other reserved (if applied) Calibration Data Blocks are the same as the first one.

Table 3.4. EEPROM Data Format

Item	Address (hex)	Content
1	0000	Calibration data block (first calibration)
2	0018	Calibration data block
3	0030	Calibration data block
4	0048	Calibration data block
5	0060	Calibration data block
6	0078	Block of synchronization
7	0082	Block of parameters of measuring
8	008C	Parameters of thermostabilization of
9	008C	Parameters of thermostabilization of Light
10	008C	Optical Unit Identifier

<sup>)</sup> used only with DX6101 Controller

Table 3.5. Format of the First Calibration Data Block

Item	Address (hex)	Content	Name	Format
1	0000	TE coolers Operating Temperature	$T_C$	int16
2	0002	Ambient Temperature of Calibration	$T_{env}$	int16
3	0004	"Zero" Value	$d_0$	float
4	0008	Polynomial Coefficient $A_0$	$A_0$	float
5	0014	Polynomial Coefficient $A_1$	$A_1$	float
6	0020	Polynomial Coefficient $A_2$	$A_2$	float
7	0024	Polynomial Coefficient $A_3$	$A_3$	float
8	0028	Polynomial Coefficient $A_4$	$A_4$	float
9	002C	Polynomial Coefficient $A_5$	$A_5$	float
10	0030	Polynomial Coefficient $A_6$	$A_6$	float



## **4. Installation Tips**

There are two external power sources required for Optical Unit supply.

An external +5V and –5V DC power sources with  $\pm 2.5\%$  output tolerance are required for Optical Unit supply. The operating current must be not less than 7.5 mA.

The power supplies are to be connected to pins X1/1 and X1/2.

They are necessary for supply of:

- preamplifier of Photodetector,
- thermistors and sensitive elements of Photo–detector,
- EEPROM.

The power supply for customer external electronics depends on scheme concepts. But one must take into account that the total current consumption of Light Emitters and TE Cooler of DX6106 Optical Unit is not more than 300 mA at 0...–5°C operating temperature of TE coolers.

For proper Optical Unit operation the ground line should be separated into three wires and joined in the one, close to power supply common terminal.

Shielding ground should be in contact with the Optical Unit housing.

The recommended connection is shown in Fig. 4.1.

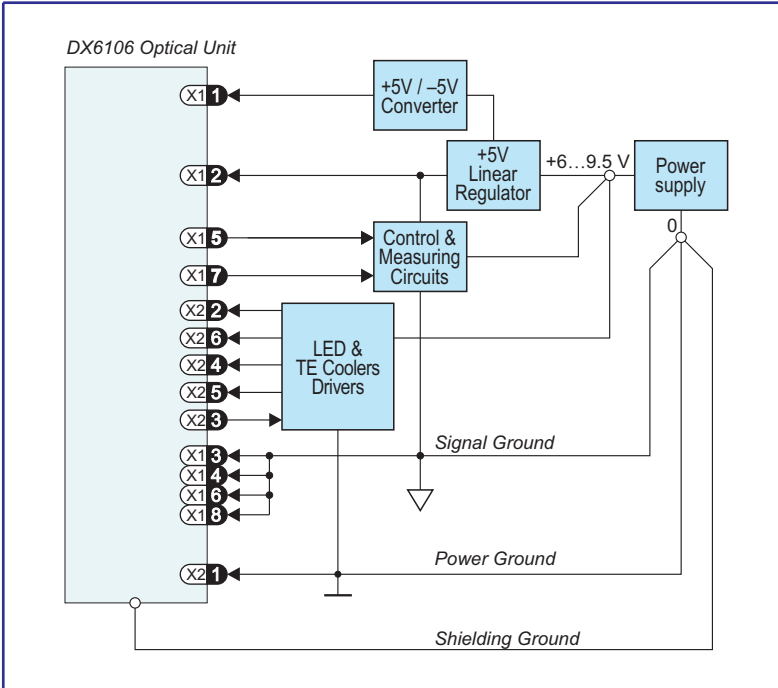

*Fig. 4.1. DX6106 power supplies connection*



## 5. Calibration

### Preparation

First of all User should prepare the set of calibration gases.

The number of calibration gases should be at least two more than the desirable polynomial order (See Chapter 2). In turn the order of a polynomial determines accuracy of approximation, and hence the measurement accuracy.

The following close to optimum set of calibration gases can be recommended (in percentages to upper concentration of measurement range):

Extended Kit	Standard Kit
0	0
1	1
5	5
10	10
15	–
30	–
50	50
65	–
100	100

Any other sets of standard samples User can apply according to own reasons. But be sure that the samples are within specified measurement range and the customer standard gases provide accurate calibration.

As a “zero” gas one can use any standard pure gas. Argon (Ar) or Nitrogen (N<sub>2</sub>) are quite suitable.

As other concentrations, the mixture of measured gas with the “zero” gas is usually used.

Prepare some portions of plastic tubes for gas bottles connection with Optical Unit’s gas inlets.

In further actions be guided by Chapter 3.

## **Zero Adjustments**

To ensure the high accuracy, simple adjustment can be made during operation to adjust "zero" ratio  $D_0$ .

The procedure requires to flow up any "zero" gas through the gas sampling cell.

The new  $D_0$  coefficient should be stored into EEPROM in place of old value after the completing adjustment procedure (See Chapter 2).

## Re – Calibration

In standard option, the DX6106 Optical Unit is delivered with one calibration data. The calibration is made at optimal operating temperature.

User can make re – calibration at any time. It is possible to do this at other operating temperatures, with larger set of reference gases (larger order polynomial) and to replace stored data by the new one.

According to customer demands the re – calibration could be done by Manufacturer on request.

On – board memory can contain itself additionally 13 data blocks for more calibrations. Totally up to 14 different calibrations could be done.

The polynomial coefficients  $A_j$  depend on the design of the Optical Unit's optical scheme. It is not necessary to make re – calibration often.

It is recommended to perform re – calibration annually.

## 6. Maintenance

### Optics Cleaning

If the output signal of either channels (or both) became appreciably less than usually, the Optical Unit's optics is most likely to require cleaning.

Cleaning of optics is executed with the help of suede and the special optic cleaning fluid.

For optics cleaning the DX6106 Optical Unit must be disassembled.

Remove screws from each end face of the Optical Unit. Remove the covers (Fig. 6.1).

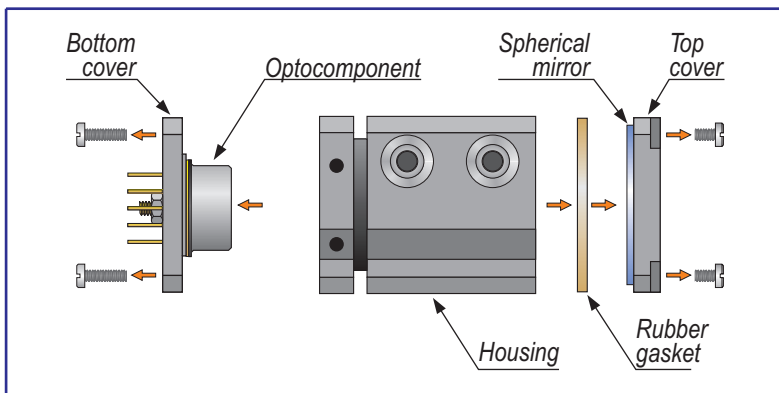

*Fig. 6.1. DX6106 Optical Unit disassembling illustration*

The Optical Unit after disassembling is shown in Fig. 6.2.



*Fig. 6.2. DX6106 Optical Unit with the*

***The spherical mirror is glued to the top cover.  
Do not try to rip it off.***

Clean now

- the window of the optopair,
- spherical mirror,
- internal mirror (with a hole) from both sides.

Wait some minutes and assemble the Optical Unit in the reverse order.

## 7. Standard Kit

#	Item	Code	Quan.
1	Optical Unit	DX6106	1
2	Interconnection cable	DX6100-C-25	1
3	Interconnection cable	DX6100-C-26	1
4	Connector's housing	ZHR-8	1
5	Connector's housing	SHR-08V-S-B	1
6	Connector's shrouded header	B8B-ZR	1
7	Connector's shrouded header	BM08B-SRSS-TB	1
8	DX6106 User Manual		1
9	DX6100 software CD		1







## 8. Specifications

### Common

<b>Type</b>	NDIR multipass scheme
<b>Detector</b>	Lead selenide with TE cooler

### Measured gases

<b>Carbon Dioxide</b>	CO <sub>2</sub>
<b>Hydrocarbons</b>	C <sub>m</sub> H <sub>n</sub>

### Operation conditions

<b>Moisture protection</b>	IP65
<b>Temperature range</b>	-10° to 50°C
<b>Relative humidity</b>	5 to 100%

### Mechanical

<b>Dimensions</b> <sup>4)</sup>	42 × 27 × 27 mm
<b>Weight</b>	60 g (max)

## Carbon Dioxide (CO<sub>2</sub>) Sensor<sup>\*)</sup>

<b>Concentration range</b> <sup>1)</sup>	0...1000 ppm	0...5 % vol	0...20 % vol
<b>Noise level</b> <sup>2,3)</sup>	< 3 ppm	< 0.15 %	< 0.15 %
<b>Accuracy</b> <sup>3)</sup>	10 ppm	0,5 %	0,5 %
<b>Zero drift</b> <sup>3)</sup>	0.02 %		

## Hydrocarbons (C<sub>m</sub>H<sub>n</sub>) Sensor<sup>\*)</sup>

<b>Concentration range</b> <sup>1)</sup>	0...1000 ppm	0...5 % vol
<b>Noise level</b> <sup>2,3)</sup>	< 2 ppm	< 0.1 %
<b>Accuracy</b> <sup>3)</sup>	10 ppm	0,5 %
<b>Zero drift</b> <sup>3)</sup>	0.02 %	

\*) *If to use with DX6101 controller.*

1) *Optional ranges up to 100% vol. are available.*

2) *At Averaging Time Constant = 0.2 s.*

3) *If value in %, then it means relative units  $\Delta X/X$*

4) *Without gas inlet pipes and 6102 module.*

## 9. Ordering Guide

XXXXXX . XX . XXX . X

### Gas Sampling Option

- A** – Aspiration
- D** – Diffusion

### Concentration Range

*The largest concentration value, in ppm, includes 2 significant digits followed by the number of zeros to follow*

### Gas Code

Code	Gas
01	CO <sub>2</sub>
02	C <sub>n</sub> H <sub>m</sub>
03	CH <sub>4</sub>
04	CO
05	H <sub>2</sub> O

### Part Number

Example:

**DX6106.01.504.A**

- [DX6106]** DX6106 Series,
- [01]** CO<sub>2</sub> Gas Option,
- [504]** 0...5.0·10<sup>4</sup> ppm (0...5%) concentration range,
- [A]** aspiration type gas cell,



RMT Ltd. Leninskij prosp. 53, Moscow 119991 Russia  
phone: 095-132-6817 fax: 095-135-0565  
e-mail: rmtcom@dol.ru <http://www.rmtltd.ru>